

AL-KO Overrun System

AL-KO

Vehicle Technology

Delta Connections to 3500 Kg

Designed for use on chassis fitted with 'A' frames, AL-KO overrun hitches are available in ten specifications to meet all your towing requirements.

In addition to the safe coupling indicator button, the new generation heads now combine a wear indicator plus an actuating handle which provides a reassuring audible signal once successful attachment has been made. Coupling has never been easier or safer!

Specified as an option on type 251S is a robust and unique, rear mount jockey wheel/prop clamp bracket. Breakaway cable guides and a skid are also offered.

To complete the system AL-KO offer two security devices; a heavy duty padlock or the AL-KO Safety Anti-Theft Device. Both security devices may be used in conjunction with the AL-KO Safety ball to prevent unauthorised towing of the trailer using a hook. The AL-KO Safety has been tested by Sold Secure and is approved to withstand a five minute attack test. Insurance discounts may be negotiated if an approved Sold Secure device is fitted.

All AL-KO overrun hitches are hot dip galvanised to ensure a long lasting weatherproof finish.

Strict quality control and quality assurance procedures ensure that the overrun hitch you order is manufactured and assembled to the highest standards.

Each overrun hitch has full EU type approval.

Specially designed for use with asbestos free, high performance auto-reverse brakes. Combined with the progressive damping characteristics of the shock absorber system, the AL-KO overrun hitch provides smooth braking operation in safety and comfort.

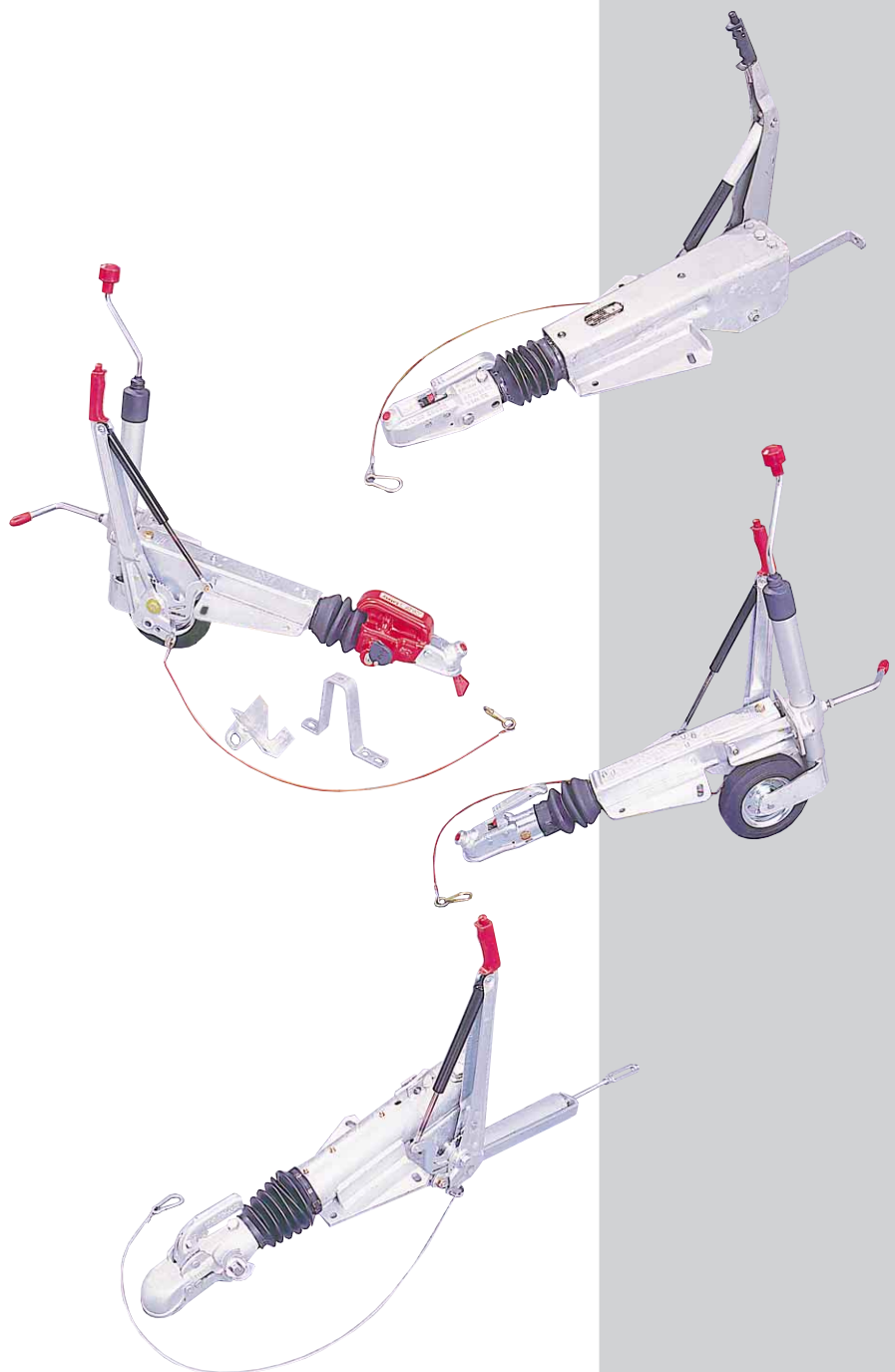

Coupling head fitted with AL-KO Safety Device & AL-KO Safety Ball.



Ak300 Coupling

AL-KO Overrun System



Specification and Technical Data

Vehicle Technology

The AL-KO overrun device is designed for use with axles and wheel brakes from the AL-KO range, but are equally suited for use with non AL-KO axles and wheel brakes providing all the technical requirements are met. Our technical department will be pleased to assist you.

- Auto-reverse for trailers over 25 km/h
- Power handbrakes on all types
- New generation coupling head with visual and audible safety indicators
- Two security devices and the AL-KO Safety ball ensure complete peace of mind. Insurance discounts may be negotiated on fitment of the AL-KO Safety device
- Heavy duty jockey/prop clamp bracket on type 251S
- Supplied complete with breakaway cable
- Full EU and German TUV type approvals

Also available from AL-KO

- Square connection overrun hitches
- Axles
- Fixed/Adjustable Height T-pole chassis
- Wheels and Tyres
- Unbraked Couplings
- Corner Steadies
- Mudguards
- Lighting
- Winches
- Jockey Wheels
- Wheel Chocks
- Security Devices
- Stabilisers

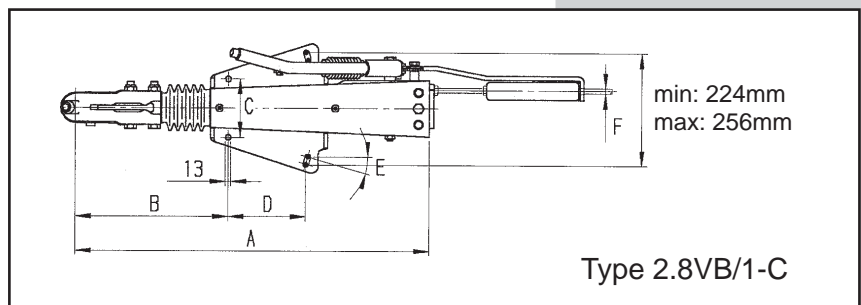
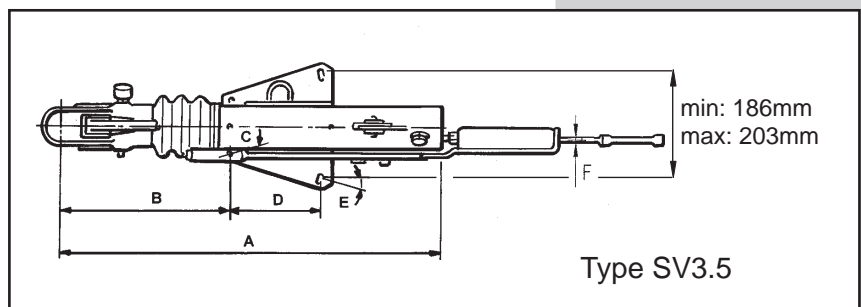
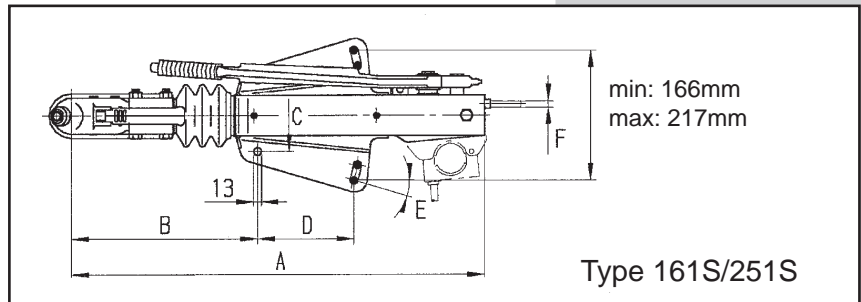
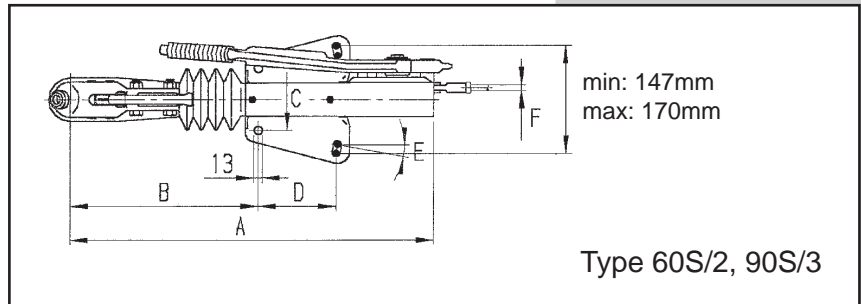

In line with our company policy of constant improvement, we reserve the right to change the specifications without notice.

Part	Type	Capacity Kg	A	B	C	D	E	F	Padlock	AL-KO Safety	Nose Load	Weight Kg	Rear Clamp Bkt	Breakaway Cable Guide	Skid	AL-KO Safety Ball (24)	Compatible Brake Type
645100	60S/2	450-750	584	302	100	125	11°-16°	M10	641257	249818	75	9	-	2082410104	217132	247104	1636G/1637
645008	90S/3	700-1000	584	302	100	125	11°-16°	M10	641257	249818	75	9	-	2082410104	217132	247104	1636G/1637/2051
626587	161S	950-1600	682	308	120	160	8°-17°	M10	641257	246961	100	12	-	364414	217132	247104	1637/2051
645011	161S	950-1600	682	308	120	160	8°-17°	M10	641257	246961	100	12	-	364414	217132	247104	2361
626568	251S	1500-2600	681	307	120	160	8°-17°	M10	641257	246961	100	14	249127	364414	217132	247104	1637/2051
645016	251S	1500-2600	681	307	120	160	8°-17°	M10	641257	246961	100	14	249127	364414	217132	247104	2361
645035	251G*	1500-3000	686	312	120	160	8°-17°	M12	641257	246961	100	16	249127	364414	217132	247104	1637/2051
645961	251G*	1500-3000	686	312	120	160	8°-17°	M12	641257	246961	100	16	249127	364414	217132	247104	2361
578533	2.8VB/1-C	2500-3500	790	330	135	180	14°-18°	M12	641257	-	150	33	-	366262	-	247104	2051/2361
273823	SV3.5	2000-3500	698	314	100	160	14°-18°	M12	-	-	120	16	-	2082410104	-	247104	2361

* Reinforced

Your Choice for all Applications

AL-KO Kober Limited, South Warwickshire Business Park, Kineton Road, Southam, Warwickshire, CV47 0AL
Tel: (01926) 818500 Fax: (01926) 818562

www.al-ko.co.uk mail@al-ko.co.uk