

Unbraked/braked Ball Couplings

AL-KO

Vehicle Technology

50mm diameter ball fitting

In addition to the existing range of unbraked ball couplings, an exciting new generation of braked couplings, for OE and replacement markets, are now available from AL-KO. Multiple fixing configurations also allow non AL-KO couplings to be replaced.

The new generation of couplings incorporate a unique wear indicator which provides advance warning that either towball or coupling may need replacement.

The new low-profile ergonomic handle, which provides extra clearance for tow vehicles with rear opening doors, also gives a reassuring audible signal once successful attachment has been made. The existing safe coupling indicator provides a visual signal ensuring coupling has never been easier or safer!

To comply with current EU approvals a secondary coupling is available for use on unbraked trailers to 750 Kg Maximum Gross Weight.

A comprehensive range of security devices complete the system. The standard barrel lock is specified for all unbraked couplings whilst a heavy duty padlock may be utilised on all braked couplings. Additionally, the AL-KO Safety Anti-Theft Device, which has been approved to withstand a five minute attack test by Sold Secure, ensures complete peace of mind when fitted to types AK 160 and AK 300. Insurance discounts may be negotiated if an approved Sold Secure device is fitted. All security devices may be used in conjunction with the AL-KO Safety Ball to prevent unauthorised towing of the trailer using a hook.



Also available from AL-KO

- Axles
- Overrun hitches-
Delta and square connections
- Wheels and Tyres
- Corner Steadies
- Mudguards
- Lights
- Winches
- Jockey Wheels
- Wheel Chocks
- Stabilisers
- Security Devices

Ball Couplings



Specification and Technical Data

Vehicle Technology

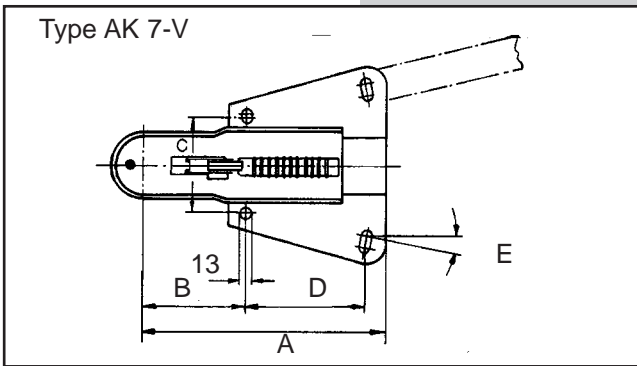
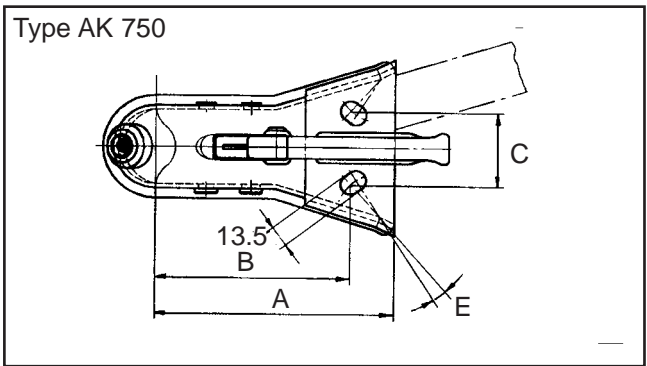
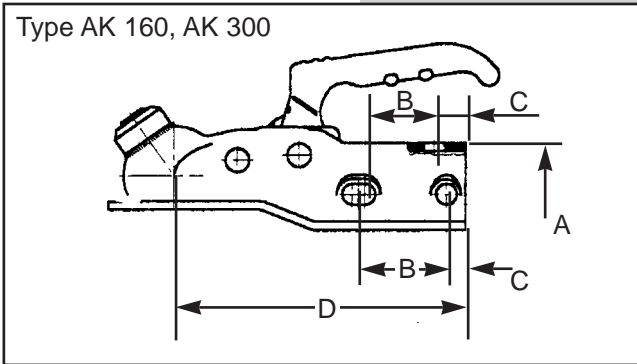
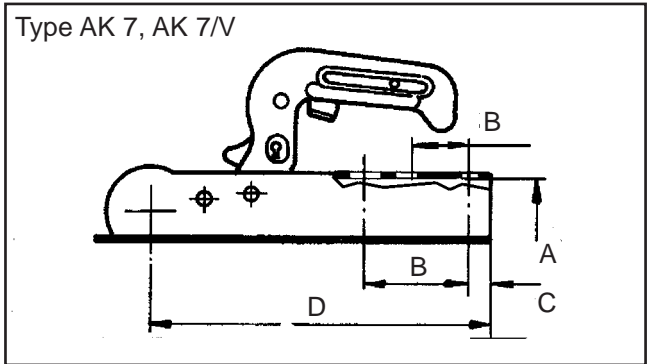

Type	Part No	Cap (Kg)	Nose Load (Kg)	Fixing A	Fix Hole Dia.	Dims			Second. Coupling	Barrel Lock	Padlock	AL-KO Safety	Weight (Kg)	AL-KO Safety Ball (24)	Comments
						B	C	D							
AK 7	203252	750	75	Ø60	vertical Ø12.2	90/116	15	236	211514	203216	-	-	1.4	247104	Unbraked use
AK 7	203253	750	75	Ø70	vertical Ø12.2	90/116	15	236	211514	203216	-	-	1.4	247104	Unbraked use
AK 7/V	203269	750	75	□ 40	vertical Ø12.2	90	15	215	211514	203216	-	-	1.5	247104	Unbraked use
AK 7/V	203254	750	75	□ 50	vertical Ø12.2	90	15	215	211514	203216	-	-	1.5	247104	Unbraked use
AK 7/V	203255	750	75	□ 60	vertical Ø12.2	90	15	215	211514	203216	-	-	1.5	247104	Unbraked use
AK 160	247162	1600	120	Ø35	horiz Ø12.2	54	15	177	-	-	641257	249818	1.6	247104	replaces AK 7, AK 10/2 part nos. 203201 & 203251
AK 160	247163	1600	120	Ø50	horiz cross Ø12.2	50, 54 40	11	168	-	-	641257	246961	1.6	247104	replaces AK 10/2 part no. 203317
AK 300	246902	3000	120	Ø50	horiz cross Ø12.2	50, 54 40	11	168	-	-	641257	246961	1.8	247104	replaces AK 252 part no. 243184
AK 350*	249164	3500	200	Ø50	horiz Ø12.2	50/54	12	175	-	-	641257	-	2.5	247104	replaces AK 251 part no. 242189
AK 350*	247619	3500	200	Ø60	horiz Ø16.2	54	14	175	-	-	641257	-	2.5	247104	replaces AK 35 part no. 294286

*cast

In line with our company policy of constant improvement, we reserve the right to change the specifications without notice.

Type	Part No	Cap (Kg)	Nose Load (Kg)	Dims					'A' Frame Angle	Second. Coupling	Barrel Lock	Padlock	AL-KO Safety	Weight (Kg)	AL-KO Safety Ball (24)	Comments
				A	B	C	D	E								
AK 7-V	202602	750	75	255	108	100	125	10°	11° - 16°	211514	203216	-	-	3	247104	unbraked A-frames
AK 750	242982	750	75	150	130	50	-	9°	17° - 26°	211514	203216	-	-	1.3	247104	unbraked A-frames

Your Choice for all Applications

AL-KO Kober Limited, South Warwickshire Business Park, Kineton Road, Southam, Warwickshire, CV47 OAL

Tel: (01926) 818500 Fax: (01926) 818562

www.al-ko.co.uk mail@al-ko.co.uk